



Gas system

SERIES 4000 NATURAL GAS

400V/50 Hz/NO_x < 500 mg/Nm³

System ratings

Gas genset with optional heat recovery module

Genset type	Engine type	Output	Therm. ²⁾	Exhaust ³⁾	Low Temp.	Energy input ⁴⁾	Efficiency		Methane number ⁵⁾
		Elect. ¹⁾					Electr.	Total	
		kW _{el}	kW _{th}	kW _{th} (°C)	kW _{th} (°C)	kW	n _{el} (%)	n _{tot} (%)	
MTU 8V4000 GS	L33	776	414	422 (120)	47 (40)	1832	42,4	88,0	≥ 70
MTU 8V4000 GS	L33	854	457	448 (120)	49 (40)	1993	42,8	88,3	≥ 80
MTU 8V4000 GS	L64 FNER	999	522	490 (120)	99 (43)	2258	44,3	89,1	≥ 72
MTU 8V4000 GS	L64	1013	503	486 (120)	69 (43)	2304	44,0	86,9	≥ 80
MTU 8V4000 GS	L64 FNER	1013	530	494 (120)	59 (43)	2287	44,3	89,1	≥ 72
MTU 12V4000 GS	L33	1287	685	659 (120)	88 (40)	2974	43,3	88,5	≥ 80
MTU 12V4000 GS	L64	1521	766	691 (120)	104 (43)	3438	44,2	85,7	≥ 80
MTU 16V4000 GS	L33	1714	1005	821 (120)	113 (40)	3991	42,9	88,7	≥ 80
MTU 16V4000 GS	L64 FNER	1999	1043	984 (120)	143 (43)	4519	44,2	89,1	≥ 72
MTU 16V4000 GS	L64	2028	996	936 (120)	127 (43)	4573	44,3	86,6	≥ 80
MTU 16V4000 GS	L64 FNER	2028	1060	995 (120)	145 (43)	4583	44,3	89,0	≥ 72
MTU 20V4000 GS	L33	2145	1196	1078 (120)	142 (40)	4990	43,0	88,6	≥ 80
MTU 20V4000 GS	L64	2538	1241	1212 (120)	176 (43)	5751	44,1	86,6	≥ 80
Hot ambient conditions									
MTU 8V4000 GS	L32	776	460	420 (120)	32 (53)	1853	41,9	89,4	≥ 80
MTU 12V4000 GS	L32	1169	652	638 (120)	43 (53)	2747	42,6	89,5	≥ 80
MTU 16V4000 GS	L32	1560	890	805 (120)	76 (53)	3651	42,7	89,2	≥ 80
MTU 16V4000 GS	L64 FNER	1999	1155	965 (120)	90 (58)	4558	43,9	90,4	≥ 80
MTU 16V4000 GS	L64 FNER	2028	1173	974 (120)	93 (58)	4622	43,9	90,3	≥ 80
MTU 20V40 00 GS	L64 FNER	2538	1441	1243 (120)	150 (58)	5781	43,9	90,3	≥ 80

- 1 Rated power at nominal voltage, power factor = 1,0 and nominal frequency
- 2 Heat output from engine cooling with tolerance of ± 8%
- 3 Heat output from exhaust (exhaust cooling to 120°C) with tolerance of ± 8%
- 4 Performance data in accordance with ISO 3046/I-2002 with tolerance of 5%
- 5 Referenced methane number

- Project specific data on request:
- different alternator voltage
 - different flow-/return-temperatures, hot cooling, methane number, installation conditions etc.
 - Container



A Rolls-Royce solution

System ratings

Gas genset with optional heat recovery module

Genset type	Engine type	Output				Energy input ⁴⁾	Efficiency		Methane number ⁵⁾
		Elect. ¹⁾	Therm. ²⁾	Exhaust ³⁾	Low Temp.		Electr.	Total	
Low methane number		kW _{el.}	kW _{th.}	kW _{th} (°C)	kW _{th} (°C)	kW	n _{el.} (%)	n _{tot} (%)	
MTU 16V4000 GS	L32 ER	1560	951	951 (120)	84 (53)	3848	40,5	89,6	≥ 60
MTU 20V4000 GS	L32 ER	1948	1180	1181 (120)	99 (53)	4812	40,5	89,5	≥ 60

- 1 Rated power at nominal voltage, power factor = 1,0 and nominal frequency
- 2 Heat output from engine cooling with tolerance of ± 8%
- 3 Heat output from exhaust (exhaust cooling to 120°C) with tolerance of ± 8%
- 4 Performance data in accordance with ISO 3046/I-2002 with tolerance of 5%
- 5 Referenced methane number

- Project specific data on request:
- different alternator voltage
 - different flow-/return-temperatures, hot cooling, methane number, installation conditions etc.
 - Container

Drawings and dimensions

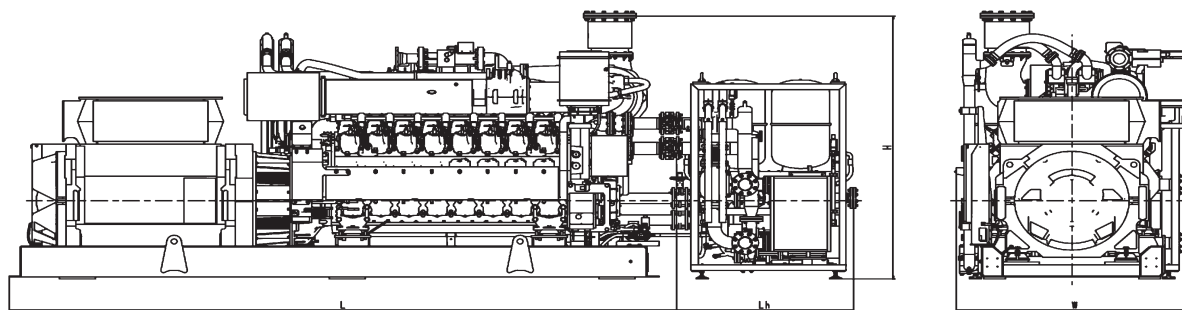

Note: This drawing is provided for reference only and should not be used for installation planning.

Genset type	Dimensions genset (LxWxH)	Heat recovery module (Lh x W x H)
MTU 8V4000 GS	4200 x 2000 x 2300 mm	1500 x 1900 x 2000 mm
MTU 12V4000 GS	5000 x 2000 x 2300 mm	1500 x 1900 x 2000 mm
MTU 16V4000 GS	5500 x 2000 x 2300 mm	1500 x 1900 x 2000 mm
MTU 20V4000 GS	6600 x 2000 x 2300 mm	1500 x 1900 x 2000 mm

Engine data

4000	
Configuration	90° V
No. of cylinders	8/12/16/20
Bore/stroke	170/210 mm
Cyl. displacement	4,77 lit.

Design and equipment (extract)

- Sliding gear starter 24V
- Gas supply with electronically controlled gas metering valve
- Electronic high-voltage capacitor ignition system with one ignition coil per cylinder
- Electronic speed governor for speed and power output control with automatic knocking control

Any specifications, descriptions, values, data or other information related to dimensions, power or other technical performance criteria of the goods as provided in this general product information are to be understood as non-binding and may be subject to further changes such as but not limited to technical evolution at any time. Version: 01.04.2015, materials and specifications subject to change without notice due to technical advances.